

Smart Wireless THUM™ Adapter

- *An installation-ready solution that provides rich WirelessHART™ data*
- *2- or 4-wire HART devices*
- *Flexibility to meet your most demanding applications*
- *Wireless output with >99% data reliability delivers rich HART data, protected by industry leading security*
- *Gain access to additional HART information, such as diagnostics or multi-variable data*
- *Add wireless to almost any measurement point*
- *WirelessHART capabilities extend the full benefits of PlantWeb® to previously inaccessible locations*



WirelessHART
Expanding the Possibilities

Contents

Wireless Overview	page 2
WirelessHART... The Industry Standard	page 3
Smart Wireless THUM Adapter	page 4
Specifications	page 5
Product Certifications	page 6
Dimensional Drawings	page 7
Ordering Information	page 8

Wireless Overview

SELF-ORGANIZING NETWORKS

The self-forming, intelligent devices provide exceptional data reliability and network stability. The Smart Wireless THUM Adapter works with existing wired devices, allowing you to use existing practices, training and maintenance procedures, without the added wiring costs.

LAYERED SECURITY KEEPS YOUR NETWORK SAFE

Emerson Process Management's layered approach to wireless network security ensures that your network stays protected. The network devices implement Encryption, Authentication, Verification, Anti-Jamming and Key Management methods to ensure that data transmissions are received only by the Wireless Gateway.

SMARTPOWER™

Emerson devices incorporate SmartPower™. SmartPower™ refers to the benefits that users enjoy due to the engineering efforts made to reduce power consumption. Emerson has power-optimized our instrumentation, both hardware and software, to extend life while still delivering highly reliable measurements with rich HART® data and diagnostic information. The THUM Adapter is a power scavenging device that requires no external battery.

RELIABLE TRANSMITTER PERFORMANCE

The THUM Adapter ensures top transmitter performance in harsh and/or noisy EMI/RFI environments.

DIGITAL FIELD DEVICES THAT POWER PLANTWEB



The THUM Adapter powers PlantWeb® by communicating important HART data and diagnostic information that ensures process health and enables economical HART architecture.

MOUNTING FLEXIBILITY

Any measurement point can be reached by connecting the THUM Adapter directly to any 2- or 4-wire HART device conduit entry, or through the use of a conduit adapter.

WIRELESS HART

The Smart Wireless THUM Adapter utilizes self-organizing network technology to deliver information rich data with >99 percent data reliability. This innovation extends the full benefits of PlantWeb® to previously inaccessible locations.

SMART WIRELESS SOLUTIONS

Smart Wireless Gateway

The Emerson Smart Wireless Gateway integrates the self-organizing network into the host system, providing industry leading security and data reliability.

Smart Wireless Field Devices

Emerson Process Management has a family of Smart Wireless products to integrate different measurement types into self-organizing network that optimizes plant performance and reduces risk to personnel. The different measurement types offered include pressure, level, flow, temperature, discrete position monitoring, pH, conductivity, and vibration.

AMS® Wireless SNAP-ON™

The AMS Wireless SNAP-ON application helps to plan and validate your wireless network using best practices. It allows for viewing of communication details graphically in real time, and maintains the health of your entire self-organizing network.

WirelessHART... The Industry Standard

Self-Organizing, Adaptive Mesh Routing

- No wireless expertise required, devices automatically find the best communication paths
- Network continuously monitors paths for degradation and repairs itself
- Adaptive behavior provides reliable, hands-off operation and simplifies network deployments, expansion and reconfiguration
- Supports both star and mesh topologies

Industry Standard Radio with Channel Hopping

- Standard IEEE 802.15.4 radios
- 2.4 GHz ISM band sliced into 16 radio-channels
- Continually “hop” across channels to avoid interference and increase reliability
- Direct Sequence spread spectrum (DSSS) technology delivers high reliability in challenging radio environment

Self-Healing Network

- If an obstruction is introduced into the mesh network, devices will automatically find the best alternate communication path. This alternate path will be created and the information will continue to flow.

Seamless Integration to Existing Hosts

- Transparent and seamless integration
- Same control system applications
- Gateways connect using industry protocols

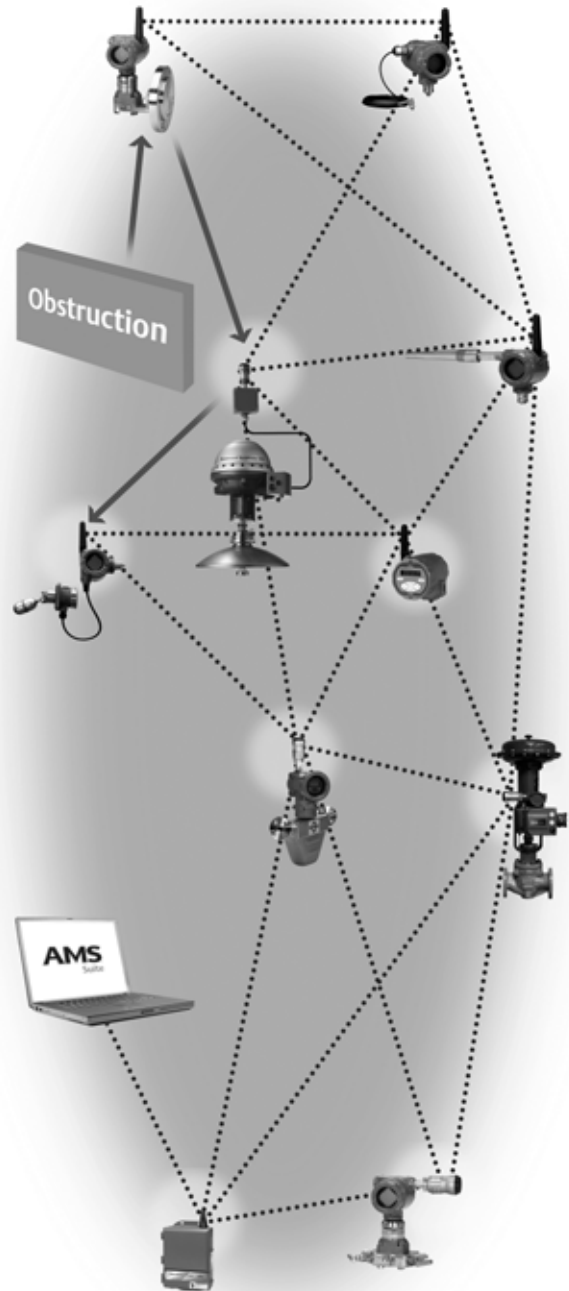

Smart Wireless THUM Adapter



Device Specifications

- Approvals: FM, CSA, ATEX, IECEx
- Input: Either 2 or 4 wire HART 5.0 device
- SmartPower™: Power scavenging technology (no battery required)



Enable Enhanced Valve Capabilities

- Online, in-service valve testing through AMS ValveLink SNAP-ON Application
- Monitor alerts such as travel deviation with AMS Device Manager, supply pressure, and electronics health
- Trend actual valve position

Gain Access to Advanced Instrument Diagnostics

- Rosemount 3051S with Advanced Process Diagnostics
- Micro Motion Coriolis Meter Verification with optional AMS Meter Verification SNAP-ON
- Rosemount Radar Echo Curve
- Rosemount Magnetic Flow Meter Verification™ with AMS Device Manager

Efficiently Gather Data from Multivariable Devices

- Rosemount 3051SMV MultiVariable™ and 3095 Mass Flow Transmitters
- Rosemount 3300 and 5300 Radar Level Transmitters
- Micro Motion Coriolis Meters
- Rosemount TankRadar Rex and TankRadar Pro
- Rosemount Magnetic Flowmeter
- Rosemount Multivariable™ Vortex Flowmeter

Make any HART Device Wireless to Enable New Measurement Points

- Level
- Flow
- Valves
- Liquid and Gas Analytical
- Pressure
- Temperature

Remotely Manage Devices and Monitor Health with AMS Device Manager

- Reduce troubleshooting time
- As found, as left data
- Calibration tracking

Specifications

Functional Specifications

Input

Any 2- or 4-wire HART powered device.

Output

WirelessHART.

Humidity Limits

0–100% relative humidity

Update Rate

User selectable, 8 sec. to 60 min.

Physical Specifications

Electrical Connections

The THUM Adapter is connected into a powered 4–20 mA loop, powering itself by scavenging power. The THUM Adapter causes a voltage drop across the loop. The drop is linear from 2.25 volts at 3.5 mA to 1.2 volts at 25 mA, but does not effect the 4–20mA signal on the loop. Under fault conditions, the maximum voltage drop is 2.5 volts.

Power Supply

Minimum load on loop 250 Ohms

To maintain normal operating functions of the sub-device, the power in the loop must have at least a 2.5 V margin at a 250 Ohm load.

HART Communicator Connections

Utilize wired device HART connections.

Materials of Construction

Enclosure

Housing - Low-copper aluminum

Paint - Polyurethane

Antenna

Poly butadine terephthalate (PBT) / Polycarbonate (PC) integrated omnidirectional antenna

Weight

.65 lbs. (.29 kg)

Enclosure Ratings

Housing option code D is NEMA 4X, and IP66.

Mounting

The THUM Adapter may be attached directly to the conduit of any 2- or 4-wire HART 5.0 device.

Performance Specifications

ElectroMagnetic Compatibility (EMC)

All Models:

Meets all relevant requirements of EN 61326-1 (2006) when installed with shielded wiring. The sub-device must also use shielded wiring for installation.

Vibration Effect

Output unaffected when tested per the requirements of IEC60770-1 field with general application or pipeline with low vibration level (10-60 Hz 0.15 mm displacement peak amplitude / 60-500 Hz 2g).

When the THUM Adapter is used on wired devices that are subject to vibration levels greater than 2g, it is recommended that the THUM Adapter be remotely mounted.

Temperature Limits

	Operating Limit	Storage Limit
	–40 to 185 °F	–40 to 185 °F
	–40 to 85 °C	–40 to 85 °C

Output Specifications

The THUM Adapter allows WirelessHART™ communication between the HART device it is connected to and the Smart Wireless Gateway.

Product Certifications

Approved Manufacturing Locations

Rosemount Inc. – Chanhassen, Minnesota, USA

European Directive Information

The EC declaration of conformity for all applicable European directives for this product can be found at www.rosemount.com. A hard copy may be obtained by contacting an Emerson Process Management representative.

ATEX Directive (94/9/EC)

Emerson Process Management complies with the ATEX Directive.

Electro Magnetic Compatibility (EMC) (2004/108/EC)

Emerson Process Management complies with the EMC Directive.

Radio and Telecommunications Terminal Equipment Directive (R&TTE) (1999/5/EC)

Emerson Process Management complies with the R&TTE Directive.

Telecommunication Compliance

All wireless devices require certification to ensure that they adhere to regulations regarding the use of the RF spectrum. Nearly every country requires this type of product certification. Emerson is working with governmental agencies around the world to supply fully compliant products and remove the risk of violating country directives or laws governing wireless device usage.

FCC and IC

This device complies with Part 15 of the FCC Rules. Operation is subject to the following conditions: This device may not cause harmful interference. This device must accept any interference received, including interference that may cause undesired operation. This device must be installed to ensure a minimum antenna separation distance of 20 cm from all persons.

Ordinary Location Certification for FM

As standard, the transmitter has been examined and tested to determine that the design meets basic electrical, mechanical, and fire protection requirements by FM, a nationally recognized testing laboratory (NRTL) as accredited by the Federal Occupational Safety and Health Administration (OSHA).

Hazardous Locations Certificates

North American Certifications

Factory Mutual (FM) Approvals

- 15** FM Intrinsic Safety and Non-incendive
Intrinsically Safe for Class I/II/III, Division 1, Groups A, B, C, D, E, F, and G.
Zone Marking: Class I, Zone 0, AEx ia IIC
Temperature Codes T4 (-50 °C ≤ T_{amb} ≤ 70 °C)
Non-incendive for Class I, Division 2, Groups A, B, C, and D.
Intrinsically safe and non-incendive when installed according to Rosemount Drawing 00775-0010.
Enclosure Type 4X/IP66

CSA - Canadian Standards Association

- 16** CSA Intrinsic Safety
Intrinsically Safe for Class I, Division 1, Groups A, B, C, and D.
T3C (-50 °C ≤ T_{amb} ≤ 70 °C)
Intrinsically safe when installed according to Rosemount Drawing 00775-0012.
Suitable for Class I, Division 2, Groups A, B, C, and D.
Enclosure Type 4X/IP66

European Certifications

- 11** ATEX Intrinsic Safety
Certificate No.: Baseefa09ATEX0125X Ⓢ II 1G
Ex ia IIC T5 (-50 °C ≤ T_{amb} ≤ 40 °C)
Ex ia IIC T4 (-50 °C ≤ T_{amb} ≤ 70 °C)
IP66
CE 1180

TABLE 1. Input Parameters

Loop Power

U_i = 30V

I_i = 200 mA

P_i = 1.0 W

C_i = 0

L_i = 0

Special conditions for safe use (X)

The surface resistivity of the antenna is greater than one gigaohm. To avoid electrostatic charge build-up, it must not be rubbed or cleaned with solvents or a dry cloth.

- N1** ATEX Type n
Certificate No.: Baseefa09ATEX0131 Ⓢ II 3 G
Ex nAnL IIC T4 (-50 °C ≤ T_{amb} ≤ 70 °C)
U_i = 45 Vdc MAX
IP66
CE 1180

Product Data Sheet

00813-0100-4075, Rev AA

July 2009

Smart Wireless THUM Adapter

IECEX Certifications

I7 IECEX Intrinsic Safety
Certificate No.: IECEX BAS 09.0050X
Ex ia IIC T5 (-50 °C ≤ T_{amb} ≤ 40°C)
Ex ia IIC T4 (-50 °C ≤ T_{amb} ≤ 70°C)
IP66

N7 IECEX Type n

Certificate No.: IECEX BAS 09.0058
Ex nAnL IIC T4 (-50 °C ≤ T_{amb} ≤ 70°C)
Ui = 45 Vdc MAX
IP66

TABLE 2. Input Parameters

Loop Power

Ui = 30V

Ii = 200 mA

Pi = 1.0 W

Ci = 0

Li = 0

Special conditions for safe use (X)

The surface resistivity of the antenna is greater than one gigaohm. To avoid electrostatic charge build-up, it must not be rubbed or cleaned with solvents or a dry cloth.

Dimensional Drawings

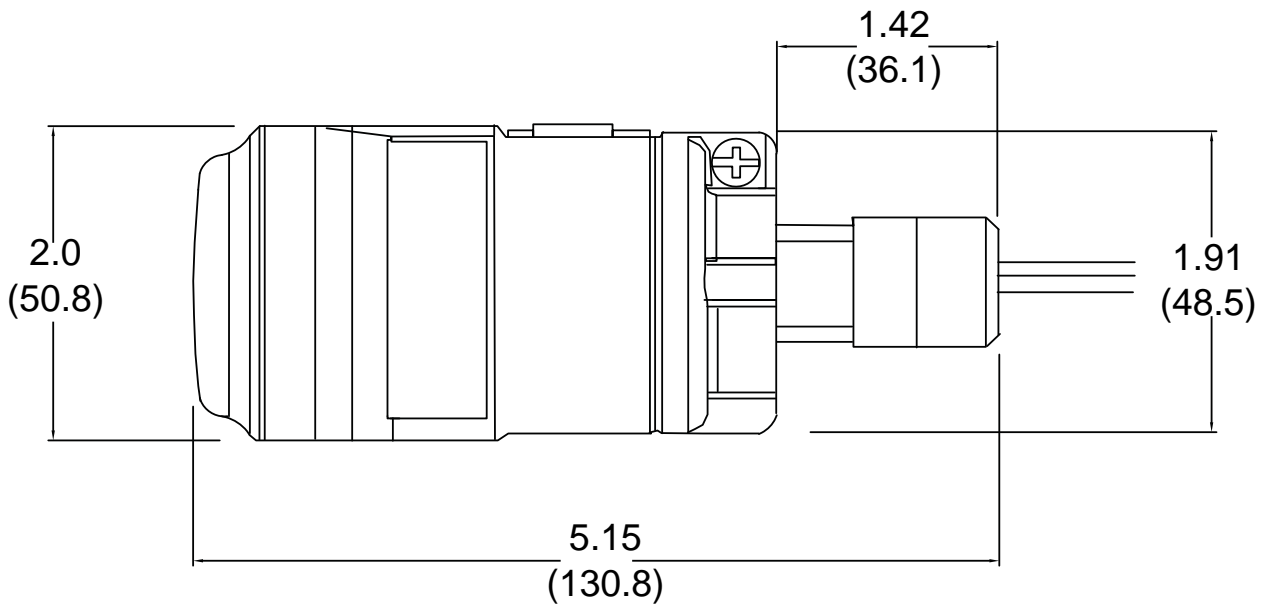

Dimensions are in inches (millimeters)

Ordering Information

Model	Product Description
775	Smart Wireless THUM Adapter
Code	Output
X	Wireless
Code	Housing
D	Aluminum
Code	Mounting Connection
1	1/2 - 14 NPT
Code	PlantWeb Functionality
1	HART [®] Data
Code	Certification
I5	FM Intrinsically Safe, Non-incendive
I6	CSA Intrinsically Safe
I1	ATEX Intrinsically Safe
I7	IECEX Intrinsically Safe
N1	ATEX Type n
N7	IECEX Type n
NA	No Approval
Wireless Transmitter Rate	
WA	User Configurable Transmit Rate
Operating Frequency and Protocol	
3	2.4 GHz DSSS, WirelessHART
Omnidirectional Wireless Antenna	
WK	Long range, Integral Antenna
SmartPower [™] Options	
9	Power Scavenging
Typical Model Number: 775XD11I5WA3WK9	

*The Emerson logo is a trade mark and service mark of Emerson Electric Co.
Rosemount and the Rosemount logotype are registered trademarks of Rosemount Inc.
PlantWeb is a registered trademark of one of the Emerson Process Management group of companies.
All other marks are the property of their respective owners.*

Standard Terms and Conditions of Sale can be found at www.rosemount.com/terms_of_sale

© 2009 Rosemount, Inc.

Rosemount Inc.
8200 Market Boulevard
Chanhassen, MN 55317 USA
T (U.S.) 1-800-999-9307
T (International) (952) 906-8888
F (952) 949-7001
www.rosemount.com

Emerson Process Management
Blegistrasse 23
P.O. Box 1046
CH 6341 Baar
Switzerland
T +41 (0) 41 768 6111
F +41 (0) 41 768 6300

Emerson FZE
P.O. Box 17033
Jebel Ali Free Zone
Dubai UAE
T +971 4 883 5235
F +971 4 883 5312

Emerson Process Management Asia Pacific Pte Ltd
1 Pandan Crescent
Singapore 128461
T +65 6777 8211
F +65 6777 0947
Service Support Hotline: +65 6770 8711
Email: Enquiries@AP.EmersonProcess.com



EMERSON
Process Management